



# Panola County Sheriff's Office

## Sheriff Sarah Fields

Office: 903-693-0333  
Fax: 903-693-9366

314 W. Wellington  
Carthage, Texas 75633

---

June 16, 2022

The Honorable David Anderson  
Panola County Judge  
110 S. Sycamore  
Carthage, Texas 75633

Dear Judge Anderson,

Please add the following item(s) to the next scheduled meeting of the Panola County Commissioner's Court:

Please record the employment of Isaiah Daniels as a Detention Officer for the Panola County Sheriff's Office at a pay rate of \$15.36 per hour effective June 25, 2022.

Sincerely,

A handwritten signature in black ink, appearing to read "Sarah Fields".

Sarah Fields  
Sheriff

SF/lw

CC: Jennifer Stacy  
Joni Reed



110 S. SYCAMORE RM 105  
CARTHAGE, TEXAS 75633  
OFFICE 903-693-0375  
FAX 903-694-2674

# COUNTY OF PANOLA

LARRY W. FIELDS  
JUSTICE OF THE PEACE, PCT. 1

June 28, 2022

Honorable David Anderson  
Commissioner Billy Alexander  
Commissioner David Cole  
Commissioner Craig Lawless  
Commissioner Dale Lagrone

Panola County Courthouse  
110 Sycamore Street  
Carthage, Texas 75633

RE: Brittany Odom Change of Status as Clerk

Dear County Judge and County Commissioners:

Please record the change of employment of Brittany Odom from Temporary Clerk with the Panola County Justice of the Peace, Precinct 1/4 office, to Part Time Clerk, Effective July 1, 2022, at the same rate of pay.

Very truly,

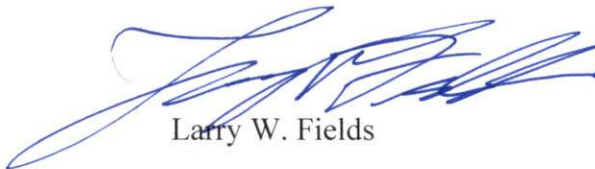

Larry W. Fields

cc: Joni Reed, County Treasurer  
Jennifer Stacy, County Auditor

NOTICE OF PROPOSED INSTALLATION  
PIPELINE AND/OR UTILITY LINES

TO: THE PANOLA COUNTY COMMISSIONER'S COURT

c/o

PANOLA COUNTY ROAD & BRIDGE DEPARTMENT, CARTHAGE, TEXAS

Formal notice is hereby given that:

TOPS Pipeline, LLC proposes to place a  
(COMPANY NAME)

16" line within the Right-of-Way  
(PIPE SIZE)

of County Road: 311 as follows:  
(NUMBER OF ROAD)

The proposed pipeline will cross under the Indicated roads on the attached sheet.  
Installation shall be made by boring a total length of 72' line in Panola County.

The location and description of the proposed line and appurtenances is more fully shown  
by the copies of the drawings attached to this notice. The line will be constructed and  
maintained on the County Right-of-Way as directed by the County Commissioners in  
accordance with current Panola County Specifications.

Construction of this line will begin on or after the 5 day of  
July 2022.

FIRM: TOPS Pipeline, LLC  
BY: Brady Dugas  
TITLE: Agent  
ADDRESS: 2200 Ross Ave., Ste. 4600 E  
Dallas, TX 75201  
PHONE: (337) 349-2026

# EXHIBIT "A"

## PANOLA COUNTY, TEXAS S.B. HENDRICKS, SURVEY, A-847



LAT: 32.321709503  
LONG: 94.254221698

**N 03°22'58" W**  
**of Proposed**  
**Pipeline**

PAN-04 & 05  
Called 68.188 Acres  
David McGee, et ux  
Volume 1684, Page 272  
P.C.O.P.R.

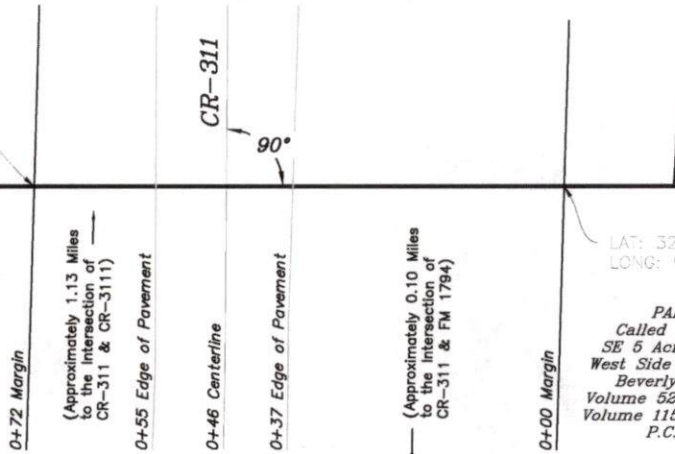

LAT: 32.310940835  
LONG: 94.254720625

PAN-03  
Called 54 Acres  
SE 5 Acres on the  
West Side of FM 1186  
Beverly Landers  
Volume 522, Page 409  
Volume 1153, Page 702  
P.C.O.P.R.

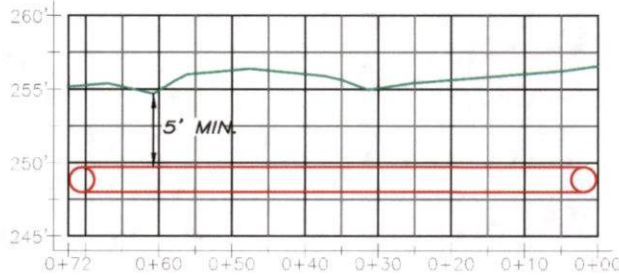

SCALE:

HORIZONTAL:  
1" : 20'

VERTICAL:  
1" : 10'



**Notes:**

1) Bearings and coordinates shown are referenced to the Texas State Plane Coordinate System, TX North Central Zone, NAD 1983

**PIPE DETAILS:**

16.00" OD, 0.375 WT, X65, ARO  
MAOP: 1440 PSI

**PLAT SHOWING:**

**RC-001**  
**PROPOSED PIPELINE CROSSING**  
**COUNTY ROAD 311**  
**S.B. HENDRICKS SURVEY, A-847**  
**PANOLA COUNTY, TEXAS**

DRAWN	JLW	DATE	06/16/22
CHECKED	AH	AFE #	
APP'D	AH		
SCALE	1"=20'	SHEET	1 OF 1
REV#	DATE	DESC.	



4901 E End Blvd South, Marshall, Tx 75672  
www.mtxsurveying.com  
903.471.8391  
TBPELS Firm No. 10194253

JOB NO.	220266
---------	--------

DRAWING NO.	220266_CR_311
-------------	---------------

PREPARED FOR:	<b>TOPS PIPELINE, LLC</b>
---------------	---------------------------

REV.	0
------	---

NOTICE OF PROPOSED INSTALLATION  
PIPELINE AND/OR UTILITY LINES

TO: THE PANOLA COUNTY COMMISSIONER'S COURT

c/o

PANOLA COUNTY ROAD & BRIDGE DEPARTMENT, CARTHAGE, TEXAS

Formal notice is hereby given that:

TOPS Pipeline, LLC proposes to place a  
(COMPANY NAME)

16" line within the Right-of-Way  
(PIPE SIZE)

of County Road: 3101 as follows:  
(NUMBER OF ROAD)

The proposed pipeline will cross under the indicated roads on the attached sheet.  
Installation shall be made by boring a total length of 30' line in Panola County.

The location and description of the proposed line and appurtenances is more fully shown by the copies of the drawings attached to this notice. The line will be constructed and maintained on the County Right-of-Way as directed by the County Commissioners in accordance with current Panola County Specifications.

Construction of this line will begin on or after the 5<sup>th</sup> day of  
July 2022.

FIRM: TOPS Pipeline, LLC  
BY: Brady Pugh  
TITLE: Agent  
ADDRESS: 2200 Ross Ave, Ste. 4600E  
Dallas, TX 75201  
PHONE: (337) 349-2026

# EXHIBIT "A"

## PANOLA COUNTY, TEXAS H. ROBERTS SURVEY, A-562



PAN-09  
N.T. Hill Estate  
Portion of Called  
195 Acres  
Described in  
VOL. 510 PG. 15  
P.C.D.R.

LAT: 32.322280064  
LONG: 94.270871247

LAT: 32.322327338  
LONG: 94.270950864

N 57°20'32" W  
Proposed  
Pipeline

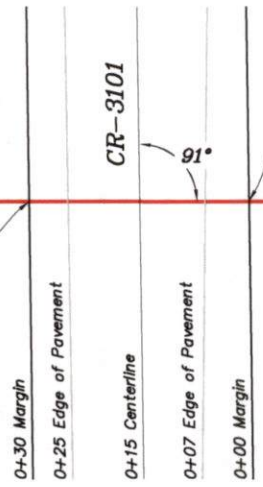

(Approximately 0.29 Miles  
to the intersection of  
CR-3101 & CR-310)

PAN-09  
N.T. Hill Estate  
Portion of Called  
195 Acres  
Described in  
VOL. 510 PG. 15  
P.C.D.R.

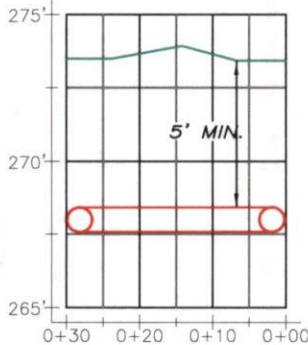

SCALE:

HORIZONTAL:  
1" : 20'

VERTICAL:  
1" : 5'

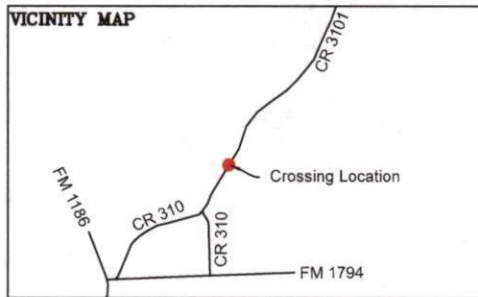

**Notes**

1) Bearings and coordinates shown are referenced to the Texas State Plane Coordinate System, TX North Central Zone, NAD 1983

**PIPE DETAILS:**

16.00" OD, 0.375 WT, X65, ARO  
MAOP: 1440 PSI

**PLAT SHOWING:**

**RC-002  
PROPOSED PIPELINE CROSSING  
COUNTY ROAD 3101  
H. ROBERTS SURVEY, A-562  
PANOLA COUNTY, TEXAS**

DRAWN	JLW	DATE	06/16/22
CHECKED	AH	AFE #	
APP'D	AH		
SCALE	1"=20'	SHEET	1 OF 1
REV#	DATE	DESC.	
JOB NO.	220266		



4901 E End Blvd South, Marshall, Tx 75672  
www.mtxsurveying.com  
903.471.8391  
TBPELS Firm No. 10194253

DRAWING NO.  
220266\_CR\_3101

PREPARED FOR:  
**TOPS PIPELINE, LLC**

REV.  
0

# APPROVAL

July 5, 2022

TO: TOPS Pipeline, LLC  
Attn: Brady Dugas  
2200 Ross Ave., Ste. 4600E  
Dallas, TX. 75201

RE: **CR #311 & #3101**

The Panola County Commissioners' Court offers no objection to the location on the right-of-way of your proposed **16" lines within** the right-of-way of County Roads **#311 & #3101** as shown by accompanying drawings and notice except as noted below.

It is expressly understood that the County Commissioners' Court does not purpose hereby, to grant any right, claim, title or easement in or upon this county road. It is further understood that in the future should for any reason the county need to work, improve, relocate, widen, increase, add to, or in any manner change the structure of this right-of-way, any required relocation of said lines shall be at the sole expense of owner.

All work on the county right-of-way shall be performed in accordance with the county instructions. The installations shall not damage any part of the road and adequate provisions must be made to cause minimum inconvenience to traffic and adjacent owners. Special specifications for placing this line are as follows:

1. All lines are to be installed a minimum of 36 inches below the flow line of the adjacent drainage or barrow ditch.
2. All excavation within the right-of-way and not under surfacing shall be backfilled by tamping in 6 inch horizontal layers. All surplus material shall be removed from the right-of-way and the excavation finished flush with surrounding natural ground.
3. Lines crossing under surfaced roads and under surfacing cross roads within the right-of-way shall be placed by boring. Boring shall extend from crown line to crown line. Gravity from sewer lines under roadways shall be cast iron pipe.
4. All lines, where practicable, shall be located to cross roadbed at approximately right angles thereto. No lines are to be installed under or within 50 feet of either end of any bridge. No lines shall be placed in any culvert or within 10 feet of the closest point of same.

5. Parallel line will be installed as near the right-of-way lines as is possible and no parallel line will be installed in the roadbed or between the drainage ditch and the roadbed without special permission of the Panola County Commissioners' Court.
6. Operations along roadbeds shall be performed in such manner that all excavated material be kept off the pavement at all times, as well as all operating equipment and materials. No equipment or installation procedures will be used which will damage any road surface or structures. The cost of any repairs to road surface, roadbed, structures or other right-of-way features as a direct result of this installation will be borne by the owner of this line.
7. Barricades, warning signs, lights, and flag man(men) when necessary shall be provided by the contractor or owner. One-half (1/2) of the traveled portion of the road must be open at all times.

Approved:   
COUNTY JUDGE

COMMISSIONERS:

Precinct #1 Billy Alexander  
Precinct #2 David A. Cole  
Precinct #3 Craig M. Lawless  
Precinct #4 Dale LaGrone



**High Pressure Pipeline – at or above 60 PSI**

**Natural Gas Pipeline, 49 CFR 192**

Project Name: Bergin Expansion Pipeline

Company: TOPS Pipeline, LLC

County: Panola County, TX

**BARLOW'S CALCULATION**

CARRIER PIPE		CASING PIPE	
1. Outside Diameter <i>in.</i> (D)	16"	1. Outside Diameter <i>in.</i>	
2. Wall Thickness <i>in.</i> (t)	.375"	2. Wall Thickness <i>in.</i>	
3. Material Specifications	API 5L PSL2 ERW	3. Material Specifications	
4. Minimum Yield Strength <i>psig</i> (S)	65,000	4. Minimum Yield Strength <i>psig</i>	
5. Location Class	1		
5. Design Factor (F)	0.6		
6. Longitudinal Seam Factor (E)	1.00		
7. Temperature Derating Factor (T)	1.00		
8. MOP/MAOP <i>psig</i>	1,440		
9. Design Pressure <i>psig</i> (P)	1,828		

The pipeline and material and design must meet minimum Federal Safety Standards stated in 49 CFR 192:

Gas Pipeline Part 192 subpart C	Liquid Pipeline Part 195 subpart C
$P = ((2 \times S \times (t/D)) \times F \times E \times T)$	$P = ((2 \times S \times (t/D)) \times E \times F)$
Design Factor (F) See § 192.111	Stream Joint Factor (E): See § 195.106
Longitudinal Joint Factor (E): See § 192.113	Design Factor (F): See § 195.106
Temperature Derating Factor (T): See § 192.115	

Gas Pipeline, Part 192

$$P = (2S(t/D)) FET = 1,828 \text{ psig}$$

$$P = \left( \frac{2(65,000)0.375}{16,000} \right) 0.60 \times 1.00 \times 1.00$$

 6/14/2022

AMP II ETX Gathering II, LLC  
Matthew J. Osborn  
President and COO

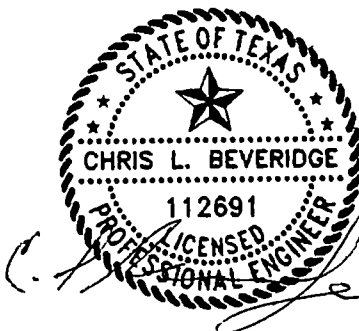

Chris Beveridge, PE  
West Fork Engineering, LLC

6/15/2022

**Stress Check for  
Steel Pipelines Crossing Highways  
as per API RP 1102**

**API RP 1102: Highway Crossing**

<b>Client</b>	: TOPS	<b>Date</b>	: 06/15/2022
<b>Project</b>	: Bergin Expansion	<b>Rev. no.</b>	: 1
<b>Subject</b>	: Location: East Texas	<b>By</b>	: CB

**Step a – Initial Design Information**

**Pipe and operational characteristics**

Outside diameter :	$D$	=	16 inch
Maximum allowable operating pressure :	$p$	=	1440 psi
Steel grade :		=	Gr X-65
Specified minimum yield strength :	$SMYS$	=	65000 psi
Type of pipe :		=	ERW
Design factor (barlow stress & fatigue check) :	$F$	=	0.6 --
Allowable design factor (equivalent stress check) :	$F_a$	=	0.6 --
Longitudinal joint factor :	$E$	=	1.00 --
Installation temperature :	$T_1$	=	Not Applicable
Maximum or minimum operating pressure :	$T_2$	=	Not Applicable
Temperature derating factor :	$T$	=	1 --
Pipe wall thickness :	$t_w$	=	0.375 inch
Corrosion allowance (pipeline) :	$CA$	=	0.0625 inch

**Installation and site characteristics:**

Cover depth :	$H$	=	10 ft
Bored diameter :	$B_d$	=	22 inch
Soil type :		=	Soft medium clays and silts (high plasticities)
Modulus of soil reaction :	$E'$	=	0.2 ksi
Resilient modulus :	$E_r$	=	5 ksi
Unit Soil Weight :	$\gamma$	=	120 lb/ft <sup>3</sup>
Type of longitudinal weld :		=	0.6 --
Design wheel load from single axle :	$P_s$	=	16 kips
Design wheel load from tandem axles :	$P_t$	=	12.5 kips
Pavement type :		=	Rigid pavement

**Other pipe steel properties:**

Young's modulus :	$E_s$	=	3.0E+007 psi
Poisson's ratio :	$\nu_s$	=	0.3 --
Coefficient of thermal expansion :	$\alpha_T$	=	6.5E-006 / °F

## Stress Check for Steel Pipelines Crossing Highways as per API RP 1102

---

### Step b – Check Allowable Barlow Stress

---

Equation 8b with:	$p = 1440$ psi	$S_{Hi}$ (Barlow) = <b>36864 psi</b>
	$D = 16$ inch	
	$t_w = 0.375$ inch	
	$F = 0.6$	
	$E = 1.00$	$F \times E \times T \times SMYS = 39000$ psi
	$T = 1$	
	$SMYS = 65000$ psi	

$S_{Hi} \leq$  Allowable?

**YES**

### Step c – Circumferential Stress due to Earth Load

---

c.1 Figure 3 with:	$t_w / D = 0.023$	$K_{He} = 2383$
	$E' = 0.2$ ksi	
c.2 Figure 4 with:	$H / B_d = 5.5$	$B_e = 1.13$
	Soil type = A	
c.3 Figure 5 with:	$B_d / D = 1.38$	$E_e = 1.40$
c.4 Equation 1 with:	$D = 16$ inch	$S_{He} = 4162$ psi
	$\gamma = 120$ lb/ft <sup>3</sup>	

### Step d - Impact Factor, $F_i$ , and Applied Design Surface Pressure, $w$

---

d.1 Figure 7 for highways with:	$H = 10$ ft	$F_i = 1.35$
d.2 Applied design surface pressure, $w$ :		
Section 4.7.2.2.1:	Rigid pavement	$P_t = 12.5$ kips
Critical case : tandem axles		$w = 86.8$ psi

---

## Stress Check for Steel Pipelines Crossing Highways as per API RP 1102

---

### Step e - Cyclic Stresses, $\Delta S_{Hh}$ and $\Delta S_{Lh}$

---

#### e.1 Cyclic circumferential Stress, $\Delta S_{Hh}$

e.1.1 Figure 14 with:  $t_w / D = 0.023$   $K_{Hh} = 17.8$   
 $E_r = 5 \text{ ksi}$

e.1.2 Figure 15 with:  $D = 16 \text{ inch}$   $G_{Hh} = 0.61$   
 $H = 10 \text{ ft (3.0 m)}$

e.1.3 Table 2 with:  $R = 0.90$   
Rigid pavement  $H = 10 \text{ ft (3.0 m)}$   $L = 1.00$   
tandem axles  $D = 16 \text{ inch}$

e.1.4 Equation 5:  $\Delta S_{Hh} = 1145 \text{ psi}$

#### e.2 Cyclic longitudinal Stress, $\Delta S_{Lh}$

e.2.1 Figure 16 with:  $t_w / D = 0.023$   $K_{Lh} = 13.8$   
 $E_r = 5 \text{ ksi}$

e.2.2 Figure 17 with:  $D = 16 \text{ inch}$   $G_{Lh} = 0.01$   
 $H = 10 \text{ ft (3.0 m)}$

e.2.3 Table 2 with:  $R = 0.90$   
Rigid pavement  $H = 10 \text{ ft (3.0 m)}$   $L = 1.00$   
tandem axles  $D = 16 \text{ inch}$

e.2.4 Equation 6:  $\Delta S_{Lh} = 15 \text{ psi}$

### Step f - Circumferential Stress dues to Internal Pressurization, $S_{Hi}$

---

Equation 7 with:  $p = 1440 \text{ psi}$   $S_{Hi} = 30000 \text{ psi}$   
 $D = 16 \text{ inch}$   
 $t_w = 0.375 \text{ inch}$

---

## Stress Check for Steel Pipelines Crossing Highways as per API RP 1102

### Step g - Principal Stresses, $S_1, S_2, S_3$

	$E_s = 3.0E+007$ psi	
	$\alpha_T = 6.5E-006$ / °F	
	$T_1 =$ Not Applicable	
	$T_2 =$ Not Applicable	
g.1 Equation 9 with:	$S_{He} = 4162$ psi	<b><math>S_1 = 35307</math> psi</b>
	$\Delta S_{Hh} = 1145$ psi	
	$S_{Hi} = 30000$ psi	
g.2 Equation 10 with:	$\Delta S_{Lh} = 15$ psi	<b><math>S_2 = 10263</math> psi</b>
	$S_{He} = 4162$ psi	
	$S_{Hi} = 30000$ psi	
g.3 Equation 11 with:	$p = 1440$ psi	<b><math>S_3 = -1440</math> psi</b>
g.4 Effective stress, $S_{eff}$ :		
Equation 12 with:	$S_1 = 35307$ psi	<b><math>S_{eff} = 32515</math> psi</b>
	$S_2 = 10263$ psi	
	$S_3 = -1440$ psi	
g.5 Check allowable effective stress	$F_a = 0.6$	
	$SMYS = 65000$ psi	
	$S_{eff} = 32515$ psi	
	$SMYS \times F_a = 39000$ psi	
	<b><math>S_{eff} \leq SMYS \times F_a?</math></b>	<b>YES</b>

### Step h – Check fatigue

h.1 Girth welds	$F = 0.6$	
Table 3		<b><math>S_{FG} = 12000</math> psi</b>
Equation 17 with:	$\Delta S_{Lh} = 15$ psi	
	$S_{FG} \times F = 7200$ psi	<b><math>\Delta S_{Lh} \leq S_{FG} \times F?</math></b>
		<b>YES</b>

## Stress Check for Steel Pipelines Crossing Highways as per API RP 1102

---

h.2 Longitudinal welds

$$F = 0.6$$

Table 3

$$S_{FL} = 23000 \text{ psi}$$

Equation 20 with:

$$\Delta S_{Hh} = 1145 \text{ psi}$$

$$S_{FL} \times F = 13800 \text{ psi}$$

$$\Delta S_{Hh} \leq S_{FL} \times F ?$$

**YES**

---



**"You call...  
...We haul!"**

**S.D. TWOMEY TRUCKING**  
**1450 HILLS LAKE ROAD**  
**CARTHAGE, TX 75633**  
**Bus: (903) 694-2231 \* Cell: (903) 690-3417**

June 20, 2022

County of Panola  
110 S. Sycamore  
Room 216-A  
Carthage, Texas 75633

Due to the rise of price increases and inflation, S.D. Twomey Trucking is asking to opt. out of our contract with The Road and Bridge Department for the year 2022. The Contract includes Arkansas SB-2, 3"x5" Georgetown Rock, and 2" Minus Crushed Iron Ore.

Please call if you have any questions or require additional information. We look forward to continuing to do business with you.

Sincerely,

Jared Twomey  
Owner

**PANOLA COUNTY  
2022  
BUDGET AMENDMENT #14**

We hereby amend the Panola County Budget for the Fiscal Year 2021 as set forth above according to the procedures outlined under Local Government Code, Chapter 111, Subchapter A Sections 111.010 (c), (d). A copy of this Order is to be filed with the County Clerk and Attached to the Budget originally adopted for 2022.

Signed on this 5 day of July, 2022.

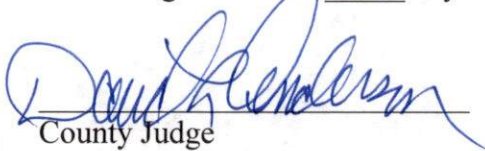
  
County Judge

  
Commissioner Precinct # 1

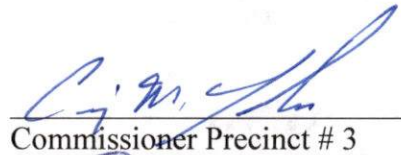
  
Commissioner Precinct # 3

  
Commissioner Precinct # 2

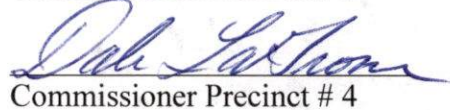
  
Commissioner Precinct # 4

Passed and approved by the Commissioners Court of Panola County on the 5<sup>th</sup> day of July, 2022 as the same appears on file in the office of the County Clerk of Panola County.

  
County Clerk



July 5, 2022





Panola County, Texas

# Budget Adjustment Report

## Adjustment Detail

For Date Range: 06/22/2022 - 07/05/2022

Account Number	Account Name	Packet Number	Post Date	Original Budget	Budget Adjustments Amount	Current Budget
<b>Budget Code: 2022 - 2022 PANOLA COUNTY BUDGET JAN-DEC Fiscal: 2022</b>						
<b>Fund: 200 - ROAD &amp; BRIDGE</b>						
<b>Revenue</b>						
<u>200-360-41020</u>	MISCELLANEOUS REVENUE			0.00	38,825.00	38,825.00
BA0001558	621: JUNE 2022 AUCTION PROCEEDS	GLPKT17826	07/05/2022		12,000.00	
BA0001559	623: JUNE 2022 AUCTION PROCEEDS	GLPKT17826	07/05/2022		15,775.00	
BA0001560	624: JUNE 2022 AUCTION PROCEEDS	GLPKT17826	07/05/2022		11,050.00	
<b>Revenue Total:</b>				<b>0.00</b>	<b>38,825.00</b>	<b>38,825.00</b>
<b>Expense</b>						
<u>200-621-53560</u>	REPAIR AND MAINTENANCE SUPPLIES			108,826.00	12,000.00	120,826.00
BA0001558	621: JUNE 2022 AUCTION PROCEEDS	GLPKT17826	07/05/2022		12,000.00	
<u>200-623-53560</u>	REPAIR AND MAINTENANCE SUPPLIES			94,950.00	50,775.00	145,725.00
BA0001544	REPLENISH	GLPKT17816	06/30/2022		11,000.00	
BA0001545	REPLENISH	GLPKT17816	06/30/2022		10,000.00	
BA0001546	REPLEISH	GLPKT17816	06/30/2022		14,000.00	
BA0001559	623: JUNE 2022 AUCTION PROCEEDS	GLPKT17826	07/05/2022		15,775.00	
<u>200-623-54080</u>	CONTINGENCY			102,488.00	-14,000.00	88,488.00
BA0001546	REPLEISH	GLPKT17816	06/30/2022		-14,000.00	
<u>200-623-55270</u>	FURNITURE & EQUIPMENT			100,000.00	-11,000.00	89,000.00
BA0001544	REPLENISH	GLPKT17816	06/30/2022		-11,000.00	
<u>200-623-55290</u>	LUMBER PILING & CULVERTS			27,400.00	-10,000.00	17,400.00
BA0001545	REPLENISH	GLPKT17816	06/30/2022		-10,000.00	
<u>200-624-53560</u>	REPAIR AND MAINTENANCE SUPPLIES			118,986.00	11,050.00	130,036.00
BA0001560	624: JUNE 2022 AUCTION PROCEEDS	GLPKT17826	07/05/2022		11,050.00	
<b>Expense Total:</b>				<b>552,650.00</b>	<b>38,825.00</b>	<b>591,475.00</b>
<b>Fund 200 Total:</b>				<b>552,650.00</b>	<b>77,650.00</b>	<b>630,300.00</b>
<b>Fund: 300 - FM &amp; LATERAL</b>						
<b>Revenue</b>						
<u>300-360-41020</u>	MISCELLANEOUS REVENUE			0.00	8,375.00	8,375.00
BA0001561	FM&L: JUNE 2022 AUCTION PROCEEDS	GLPKT17826	07/05/2022		8,375.00	
<b>Revenue Total:</b>				<b>0.00</b>	<b>8,375.00</b>	<b>8,375.00</b>
<b>Expense</b>						
<u>300-629-53560</u>	REPAIR AND MAINTENANCE SUPPLIES			31,627.00	8,375.00	40,002.00
BA0001561	FM&L: JUNE 2022 AUCTION PROCEEDS	GLPKT17826	07/05/2022		8,375.00	
<b>Expense Total:</b>				<b>31,627.00</b>	<b>8,375.00</b>	<b>40,002.00</b>
<b>Fund 300 Total:</b>				<b>31,627.00</b>	<b>16,750.00</b>	<b>48,377.00</b>
<b>Budget Code 2022 Total:</b>				<b>584,277.00</b>	<b>94,400.00</b>	<b>678,677.00</b>

**Budget Adjustment Report**

For Date Range: 06/22/2022 - 07/05/2022

Account Number	Account Name	Packet Number	Post Date	Original Budget	Budget Adjustments	Current Budget
Adjustment Number	Adjustment Description				Amount	
<b>Budget Code: 2022 PROB - 2022 PROBATION Fiscal: 2022 PROBATION</b>						
<b>Fund: 552 - REGIONAL DIVERSION ALTERNATIVES PROGRAM</b>						
<b>Revenue</b>						
<a href="#">552-330-40500</a>	STATE AID			-1,277.00	-64.00	-1,341.00
BA0001542	GRANT R - VALIDATED RISK AND NEEDS ASS	GLPKT17794	07/05/2022		-64.00	
			<b>Revenue Total:</b>	<b>-1,277.00</b>	<b>-64.00</b>	<b>-1,341.00</b>
<b>Expense</b>						
<a href="#">552-810-59970</a>	EXT CONT COMM BASED PROGRAMS			1,277.00	64.00	1,341.00
BA0001542	GRANT R - VALIDATED RISK AND NEEDS ASS	GLPKT17794	07/05/2022		64.00	
			<b>Expense Total:</b>	<b>1,277.00</b>	<b>64.00</b>	<b>1,341.00</b>
			<b>Fund 552 Total:</b>	<b>0.00</b>	<b>0.00</b>	<b>0.00</b>
			<b>Budget Code 2022 PROB Total:</b>	<b>0.00</b>	<b>0.00</b>	<b>0.00</b>

**Description**

**Fund Summary**

Description	Fund	Original Budget	Budget Adjustments	Current Budget
<b>Budget Code: 2022 - 2022 PANOLA COUNTY BUDGET JAN-DEC Fiscal: 20</b>				
	200	552,650.00	77,650.00	630,300.00
	300	31,627.00	16,750.00	48,377.00
	<b>Budget Code 2022 Total:</b>	<b>584,277.00</b>	<b>94,400.00</b>	<b>678,677.00</b>
<b>Budget Code: 2022 PROB - 2022 PROBATION Fiscal: 2022 PROBATION</b>				
	552	0.00	0.00	0.00
	<b>Budget Code 2022 PROB Total:</b>	<b>0.00</b>	<b>0.00</b>	<b>0.00</b>



LSO Auctions  
 4629 Mark IV Pkwy  
 Ft Worth, TX 76106  
 817-740-9400 FAX 817-740-9777  
 Iso.cc

Seller Number: 99  
 Panola County  
 Panola County  
 1121 E Sabine Carthage, TX 75633  
 Phone 9036930320

Statement Date: 06/30/2022  
 Email: jstacy@co.panola.tx.us

Consignor Final Statement Report for Panola County (06/24/22)  
 Closed On 06/24/2022

Item Num	Buyer Name	Phone/Fax	Winning Bid	Tax	Surcharge & Fees	Total
<b>2994-43212</b>	Quintus A Raider 74 Itz Britz Rd Fredericksburg, TX 78624	830-998-5151				
93246	Lot: 05 - 2011 FORD F-350 TRUCK		\$ 6,750.00	\$ 0.00	\$ 675.00	\$ 7,425.00
<b>Totals:</b>			\$ 6,750.00	\$ 0.00	\$ 675.00	\$ 7,425.00
<b>2994-43213</b>	Shawn Ablett none 109 Grayson Street Whitesboro, TX 76273	214-578-6729				
93254	Lot: M3 - UTILITY FLAT BED		\$ 1,100.00	\$ 102.55	\$ 143.00	\$ 1,345.55
<b>Totals:</b>			\$ 1,100.00	\$ 102.55	\$ 143.00	\$ 1,345.55
<b>2994-43214</b>	Jose Cordova 22543 Sweetglen Ct Spring, TX 77373	3464976126				
93247	Lot: 06 - 2013 FORD TAURUS		\$ 2,200.00	\$ 0.00	\$ 286.00	\$ 2,486.00
<b>Totals:</b>			\$ 2,200.00	\$ 0.00	\$ 286.00	\$ 2,486.00
<b>2994-43215</b>	Ervin Dawkins Trinity Claims Service LLC 102 iron bridge rd Rosser, TX 75157	9729080506				
93256	Lot: M5 - RAMSEY WINCH AUTO CRANE		\$ 1,600.00	\$ 149.16	\$ 208.00	\$ 1,957.16
<b>Totals:</b>			\$ 1,600.00	\$ 149.16	\$ 208.00	\$ 1,957.16
<b>2994-43216</b>	Rogelio Gonzalez 2723 Meander Rd Granbury, TX 76049	8178003067 8176254141				
93255	Lot: M4 - FLAT BED		\$ 1,200.00	\$ 111.87	\$ 156.00	\$ 1,467.87
<b>Totals:</b>			\$ 1,200.00	\$ 111.87	\$ 156.00	\$ 1,467.87

<b>2994-43217</b>	Francisco Hernandez california konection 2406 S Jupiter Rd suite 5 Garland, TX 75041	2145495030				
93260	Lot: M9 - CUB CADET GARDEN PLOW		\$ 200.00	\$ 18.65	\$ 26.00	\$ 244.65
<b>Totals:</b>			\$ 200.00	\$ 18.65	\$ 26.00	\$ 244.65
<b>2994-43218</b>	Keith Jackson Jackson Equipment Sales 1018 N Ellis Groesbeck, TX 76642	2547446333				
93244	Lot: 02 - *Updated 06/20/22* 2009 FORD F750XL DUMP TRUCK		\$ 12,050.00	\$ 0.00	\$ 1,205.00	\$ 13,255.00
93245	Lot: 04 - *Updated 06/20/22* 2012 FORD F-750 DUMP TRUCK		\$ 11,050.00	\$ 0.00	\$ 1,105.00	\$ 12,155.00
<b>Totals:</b>			\$ 23,100.00	\$ 0.00	\$ 2,310.00	\$ 25,410.00
<b>2994-43219</b>	Austin Jones River Auto Sales 1800 E. Lancaster Ave Fort Worth, TX 76103	8175033966				
93251	Lot: 10 - 2013 FORD F-150 TEXAS EDITION PICKUP		\$ 5,750.00	\$ 0.00	\$ 575.00	\$ 6,325.00
<b>Totals:</b>			\$ 5,750.00	\$ 0.00	\$ 575.00	\$ 6,325.00
<b>2994-43220</b>	JUAN MARTI CESAR TX AUTO SALES LLC 7908 Bedford Euless Rd Suite 300 North Richland Hills, TX 76180	7862033003				
93248	Lot: 07 - 2016 CHEVROLET EQUINOX SUV		\$ 4,500.00	\$ 0.00	\$ 450.00	\$ 4,950.00
<b>Totals:</b>			\$ 4,500.00	\$ 0.00	\$ 450.00	\$ 4,950.00
<b>2994-43222</b>	Joan Portillo 2921 briarpark dr Apt 527 Houston, TX 77042	3468180816				
93250	Lot: 09 - 2013 CHEVROLET TAHOE SUV		\$ 4,000.00	\$ 0.00	\$ 520.00	\$ 4,520.00
<b>Totals:</b>			\$ 4,000.00	\$ 0.00	\$ 520.00	\$ 4,520.00
<b>2994-43223</b>	Arthur Russell Russell Sheffield 11250 CR 105 Brownwood, TX 76801	2547444905				
93249	Lot: 08 - 2002 FORD VAN		\$ 11,000.00	\$ 0.00	\$ 1,100.00	\$ 12,100.00
<b>Totals:</b>			\$ 11,000.00	\$ 0.00	\$ 1,100.00	\$ 12,100.00

**2994-43224** Garry Scott 5205862824  
 507 Franklin st  
 Cleburne, TX  
 76033

93243	Lot: 01 - 2012 FORD F-550 TRUCK	\$ 12,000.00	\$ 0.00	\$ 1,200.00	\$ 13,200.00
<b>Totals:</b>		\$ 12,000.00	\$ 0.00	\$ 1,200.00	\$ 13,200.00

**2994-43225** Fernando Vazquez 18177735329  
 3001 hickory  
 street Dallas  
 Dallas, TX 75226

93257	Lot: M6 - HOFFMAN TIRE BALANCER	\$ 25.00	\$ 2.33	\$ 3.25	\$ 30.58
<b>Totals:</b>		\$ 25.00	\$ 2.33	\$ 3.25	\$ 30.58

**2994-43226** Justin Waltz 9365812055  
 Waltz Ranch  
 975 FM 1696 West  
 Huntsville, TX  
 77320

93252	Lot: M1 - 2014 MODERN PREDATOR 10-FT FLEX MOWER	\$ 1,000.00	\$ 0.00	\$ 130.00	\$ 1,130.00
<b>Totals:</b>		\$ 1,000.00	\$ 0.00	\$ 130.00	\$ 1,130.00

**2994-43227** David Allen Wells 281-622-1003  
 David Wells 281-593-3733  
 407 Austin St  
 Cleveland, TX  
 77327

93253	Lot: M2 - 2011 MODERN PREDATOR 10-FT FLEX MOWER	\$ 425.00	\$ 39.62	\$ 55.25	\$ 519.87
93259	Lot: M8 - TROY BILT GARDEN PLOW	\$ 125.00	\$ 11.65	\$ 16.25	\$ 152.90
<b>Totals:</b>		\$ 550.00	\$ 51.27	\$ 71.50	\$ 672.77
<b>Totals:</b>		\$ 74,975.00	\$ 435.83	\$ 7,853.75	\$ 83,264.58

**Summary of Sales Activity at Panola County (06/24/22)**

Commissions are Calculated on a Percent of the Sale Price of EACH LOT.

Commission Summary:

Commission Description	Commission Rate	Amount Sold	Comm. Amount
	0.00%	\$ 74,975.00	\$ 0.00

**Statement Totals**

**17 Lots Sold.**

<b>Total Sales:</b>	\$ 74,975.00
<b>Less All Expenses:</b>	\$ 0.00
<b>Less Commissions:</b>	\$ 0.00
<b>Total Amount Due:</b>	\$ 74,975.00
<b>Sales Tax Collected:</b>	\$ 435.83



Panola County, Texas

# Budget Adjustment Register

## Adjustment Detail

Packet: GLPKT17826 - Auto Process - GL Budget Adjustment

Adjustment Number	Budget Code	Description	Adjustment Date
BA0001558	2022 PANOLA COUNTY BU...	621: JUNE 2022 AUCTION PROCEEDS	7/5/2022

**Summary Description:**

Account Number	Account Name	Adjustment Description	Before	Adjustment	After
<a href="#">200-360-41020</a>	MISCELLANEOUS REVENUE	621: JUNE 2022 AUCTION PROCEEDS	0.00	12,000.00	12,000.00
July:	12,000.00				
<a href="#">200-621-53560</a>	REPAIR AND MAINTENANCE SU	621: JUNE 2022 AUCTION PROCEEDS	108,826.00	12,000.00	120,826.00
July:	12,000.00				

Adjustment Number	Budget Code	Description	Adjustment Date
BA0001559	2022 PANOLA COUNTY BU...	623: JUNE 2022 AUCTION PROCEEDS	7/5/2022

**Summary Description:**

Account Number	Account Name	Adjustment Description	Before	Adjustment	After
<a href="#">200-360-41020</a>	MISCELLANEOUS REVENUE	623: JUNE 2022 AUCTION PROCEEDS	0.00	15,775.00	15,775.00
July:	15,775.00				
<a href="#">200-623-53560</a>	REPAIR AND MAINTENANCE SU	623: JUNE 2022 AUCTION PROCEEDS	129,950.00	15,775.00	145,725.00
July:	15,775.00				

Adjustment Number	Budget Code	Description	Adjustment Date
BA0001560	2022 PANOLA COUNTY BU...	624: JUNE 2022 AUCTION PROCEEDS	7/5/2022

**Summary Description:**

Account Number	Account Name	Adjustment Description	Before	Adjustment	After
<a href="#">200-360-41020</a>	MISCELLANEOUS REVENUE	624: JUNE 2022 AUCTION PROCEEDS	0.00	11,050.00	11,050.00
July:	11,050.00				
<a href="#">200-624-53560</a>	REPAIR AND MAINTENANCE SU	624: JUNE 2022 AUCTION PROCEEDS	118,986.00	11,050.00	130,036.00
July:	11,050.00				

Adjustment Number	Budget Code	Description	Adjustment Date
BA0001561	2022 PANOLA COUNTY BU...	FM&L: JUNE 2022 AUCTION PROCEEDS	7/5/2022

**Summary Description:**

Account Number	Account Name	Adjustment Description	Before	Adjustment	After
<a href="#">300-360-41020</a>	MISCELLANEOUS REVENUE	FM&L: JUNE 2022 AUCTION PROCEEDS	0.00	8,375.00	8,375.00
July:	8,375.00				
<a href="#">300-629-53560</a>	REPAIR AND MAINTENANCE SU	FM&L: JUNE 2022 AUCTION PROCEEDS	31,627.00	8,375.00	40,002.00
July:	8,375.00				

**Budget Code Summary**

Budget	Budget Description	Account	Account Description	Before	Adjustment	After
2022	2022 PANOLA COUNTY BU	<a href="#">200-360-41020</a>	MISCELLANEOUS REVENUE	0.00	38,825.00	38,825.00
		<a href="#">200-621-53560</a>	REPAIR AND MAINTENANCE SUPP	108,826.00	12,000.00	120,826.00
		<a href="#">200-623-53560</a>	REPAIR AND MAINTENANCE SUPP	129,950.00	15,775.00	145,725.00
		<a href="#">200-624-53560</a>	REPAIR AND MAINTENANCE SUPP	118,986.00	11,050.00	130,036.00
		<a href="#">300-360-41020</a>	MISCELLANEOUS REVENUE	0.00	8,375.00	8,375.00
		<a href="#">300-629-53560</a>	REPAIR AND MAINTENANCE SUPP	31,627.00	8,375.00	40,002.00
			<b>2022 Total:</b>	<b>389,389.00</b>	<b>94,400.00</b>	<b>483,789.00</b>
			<b>Grand Total:</b>	<b>389,389.00</b>	<b>94,400.00</b>	<b>483,789.00</b>



**Fund Summary**

Fund	Before	Adjustment	After
Budget Code:2022 - 2022 PANOLA COUNTY BUDGET JAN-DEC Fiscal: 2022			
200	357,762.00	77,650.00	435,412.00
300	31,627.00	16,750.00	48,377.00
<b>Budget Code 2022 Total:</b>	<b>389,389.00</b>	<b>94,400.00</b>	<b>483,789.00</b>
<b>Grand Total:</b>	<b>389,389.00</b>	<b>94,400.00</b>	<b>483,789.00</b>

PANOLA COUNTY, TEXAS

**INVITATION TO BID**

RETURN BID TO:

COUNTY JUDGE  
PANOLA COUNTY COURTHOUSE, ROOM 216A  
CARTHAGE, TEXAS 75633

The enclosed INVITATION TO BID (ITB) and accompanying SPECIFICATIONS AND BID SHEET are for your convenience in bidding the enclosed referenced service/products for Panola County.

Sealed bids shall be received no later than:

**1:30 P.M., TUESDAY, AUGUST 2, 2022.**

MARK ENVELOPE

**“CONCRETE / IRON ORE”**

Bidder shall sign and date the bid. Bids, which are not signed and dated, can be rejected. Bids must be submitted on the enclosed bid sheets and must be in ink or typewritten.

Panola County appreciates your time and effort in preparing this bid. Please note that all bids must be received at the designated location by the deadline shown. Bids received after the deadline will not be considered for the award of the contract, and shall be considered void and unacceptable. Opening is scheduled to be held in Commissioners Courtroom, Panola County Courthouse, Carthage, Texas. You are invited to attend.

---

SIGNATURE OF BIDDER

**PANOLA COUNTY  
INVITATION TO BID**

**INSTRUCTIONS/TERMS OF CONTRACT**

By order of the Commissioners Court of Panola County, Texas, sealed bids will be received for:

**CONCRETE / IRON ORE**

To provide for an annual contract commencing **August 2, 2022** and continuing to **December 31, 2022**.

IT IS UNDERSTOOD that the Commissioners Court of Panola County, Texas reserves the right to reject any or all bids for any or all products and/or services covered in this bid request and to waive informalities or defects in bids or to accept such bids as it shall deem to be in the best interests of Panola County.

BIDS MUST BE submitted on the bid forms included for that purpose in this packet. Bids shall be placed in separate sealed envelopes, with **each page manually signed by a person having the authority to bind the firm in a contract** and marked clearly on the outside as shown below.

SUBMISSION OF BIDS: Sealed bids shall be submitted to:

**COUNTY JUDGE  
PANOLA COUNTY COURTHOUSE, ROOM 216A  
CARTHAGE, TEXAS 75633**

Not later than **1:30 P.M., TUESDAY, AUGUST 2, 2022**

MARK ENVELOPES:

**ALL BIDS MUST BE RECEIVED IN THE COUNTY JUDGE'S OFFICE  
BEFORE OPENING DATE AND TIME**

\_\_\_\_\_  
SIGNATURE OF BIDDER

**INVITATION TO BID**  
**INSTRUCTIONS / TERMS OF CONTRACT**

**FUNDING:** Funds for payment have been provided through the Panola County Budget adopted by the Commissioners Court for **August 2, 2022 thru December 31, 2022.**

**LATE BIDS:** Bids received in the County Judge's Office after submission deadline will be considered void and unacceptable. Panola County is not responsible for lateness or non-delivery of mail, carrier, etc.

**ALTERING BIDS:** Bids cannot be altered or amended after submission deadline. Any interlineation, alteration or erasure made before opening time must be initialed by the signer of the bid, guaranteeing authenticity.

**WITHDRAWAL OF BID:** A bid may not be withdrawn or canceled by the bidder without the permission of the county for a period of ninety (90) days following the date designated for the receipt of bids, and bidder so agrees upon submittal of their bid.

**SALES TAX:** Panola County is exempt by law from payment of Texas Sales Tax and Federal Excise Tax; therefore, the bid shall not include sales taxes.

**BID AWARD:** Panola County reserves the right to award bids on the lump sum or unit price basis, whichever is in the best interest of the county.

**CONTRACT:** This bid, when properly accepted by Panola County, shall constitute a contract equally binding between the successful bidder and Panola County. No different or additional terms will become a part of this contract with the exception of Change Orders.

**CHANGE ORDERS:** No oral statement of any person shall modify or otherwise change, or affect the terms, conditions or specifications stated in the resulting contract. All change orders to the contract will be made in writing by the Panola County Judge.

**IF DURING THE** life of the contract, the successful bidder's net prices to other customers for items awarded herein are reduced below the contracted price, it is understood and agreed that the benefits of such reduction shall be extended to Panola County.

**DELIVERY:** All delivery fees and freight or handling charges shall be as stated on the bid and contract forms section and if not so stated no such costs, fee or charge will be paid.

**CONFLICT OF INTEREST: No public official shall have interest in this contract, in accordance with Vernon's Texas Codes Annotated, Local Government Code Title 5, Subtitle C, Chapter 171.**

---

**Signature of Bidder**

**ETHICS:** The bidder shall not offer or accept gifts or anything of value nor enter into any business arrangement with any employee, official or agent of Panola County.

**EXCEPTIONS / SUBSTITUTIONS:** All bids meeting the intent of this invitation to bid will be considered for award. Bidders taking exception to the specifications, or offering substitutions, shall state these exceptions in the section provided or by attachment as part of the bid. The absence of such a list shall indicate that the bidder has not taken exceptions and shall hold the bidder responsible to perform in strict accordance with the specifications of the invitation. Panola County Commissioners Court reserves the right to accept any and all or none of the exceptions(s) / substitution(s) deemed to be in the best interest of the county.

**DESCRIPTIONS:** Any reference to model and/or make/maker used in bid specifications is descriptive, not restrictive. It is used to indicate the type and quality desired. Bids on items of like quality will be considered.

**ADDENDA:** Any interpretations, corrections or changes in this "Invitation to Bid and Specifications" will be made by addenda. Sole issuing authority of addenda shall be vested in Panola. Addenda will be mailed to all who are known to have received a copy of this Invitation to Bid. Bidders shall acknowledge receipt of all addenda.

**BIDS MUST COMPLY** with all federal, state, county and local laws concerning these types of service.

**DESIGN, STRENGTH, QUALITY** of materials must conform to the highest standards of manufacturing practice.

**MINIMUM STANDARDS FOR RESPONSIBLE PROSPECTIVE BIDDERS:** A prospective bidder must affirmatively demonstrate bidder's responsibility. A prospective bidder must meet the following requirements:

1. Have adequate financial resources, or the ability to obtain such resources as required;
2. be able to comply with the required or proposed delivery schedule;
3. Have a satisfactory record of performance;
4. Have a satisfactory record of integrity and ethics;
5. Be otherwise qualified and eligible to receive an award.

Panola County may request representation and other information sufficient to determine bidder's ability to meet these minimum standards listed above.

---

Signature of Bidder

**REFERENCES:** Panola County may request bidder to supply a list of at least three (3) references where like services/products have been supplied by their firm.

**BIDDER SHALL PROVIDE** with this bid response, all documentation required by this ITB. Failure to provide this information may result in rejection of bid.

**WAGES:** Successful bidder shall pay or cause to be paid, without cost or expense to Panola County, all Social Security, Unemployment and Federal Income Withholding Taxes of all such employees and all such employees shall be paid wages and benefits as required by Federal and/or State Law.

**TERMINATION OF CONTRACT:** This contract shall remain in effect until contract expires, delivery and acceptance of products and/or performance of services ordered or terminated by either party with a thirty (30) days written notice prior to any cancellation. The successful bidder must state therein the reasons for such cancellation. Panola County reserves the right to award canceled contract to next lowest and best bidder as it deems to be in the best interest of the county.

**PRICE CHANGES:** Prices are subject to change during the term of this contract. (See escalation/De-escalation below). Price changes will not be considered for the first sixty (60) days after the bid has been awarded.

**ESCALATION/DE-ESCALATION:** Where a bid is awarded with escalation/de-escalation pricing, the vendor is required to give a 30-day written notice before price increases. No notice requesting an increase in price shall be given or considered within the first 60 days after the bid has been awarded or a price has been escalated or de-escalated. Requested increase must be a factor beyond the control of the bidder and proof of increase must be documented and forwarded to the County Auditor. Notice of increase will be subject to approval by the Commissioners' Court before acceptance. Any contract awarded with an escalation clause shall be subject to de-escalation in the event of cost reduction.

**TERMINATION FOR DEFAULT:** Panola County reserves the right to enforce the performance of this contract in any manner prescribed by law or deemed to be in the best interest of the county in the event of breach or default of this contract. Panola County reserves the right to terminate the contract immediately in the event the successful bidder fails to:

1. Meet schedules;
2. Defaults in the payment of any fees; or
3. Otherwise, perform in accordance with these specifications.

Breach of contract or default authorizes the county to exercise any of all of the following rights:

1. Panola County may take possession of the assigned premises and any fees accrued or becoming due to date.
2. Panola County may take possession of all goods, fixtures and materials of successful bidder therein and may foreclose its lien against such personal property, applying the proceeds toward fees due or thereafter becoming due.

---

Signature of Bidder

In the event the successful bidder shall fail to perform, keep or observe any of the terms and conditions to be performed, kept or observed, Panola County shall give the successful bidder written notice of such default; and in the event said default is not remedied to the satisfaction and approval of the county within two (2) working days of receipt of such notice by the successful bidder, default will be declared and all the successful bidder's rights shall terminate.

Bidder, in submitting this bid, agrees that Panola County shall not be liable to prosecution for damages in the event that the county declares the bidder in default.

**NOTICE:** Any notice provided by this bid (or required by Law) to be given to the successful bidder by Panola County shall be conclusively deemed to have been given and received on the next day after such written notice has been deposited in the mail in Carthage, Texas, by Registered or Certified Mail with sufficient postage affixed thereto, addressed to the successful bidder at the address so provided; provided this shall not prevent the giving of actual notice in any other manner.

**PATENTS / COPYRIGHTS:** The successful bidder agrees to protect Panola County from claims involving infringement of patents and/or copyrights.

**CONTRACT ADMINISTRATOR:** Under this contract, Panola County may appoint a contract administrator with designated responsibility to ensure compliance with contract requirements. The contract administrator will serve as liaison between Panola County and the successful bidder.

**PURCHASE ORDER:** A purchase order(s) shall be generated by Panola County to the successful bidder. The purchase order number must appear on all itemized invoices and packing slips. Panola County will not be held responsible for any orders placed/delivered without a valid current purchase order number.



**INVOICES** shall show (a) name and address of successful bidder, (b) Panola County Purchase Order number, and (c) descriptive information as to the item(s) delivered.

**PAYMENT** will be made upon receipt and acceptance by the county of item(s) ordered and receipt of a valid invoice, in accordance with the State of Texas Prompt Payment Act, Government Code Chapter 2251. Successful bidder is required to pay subcontractors within ten (10) days.

\_\_\_\_\_  
Signature of Bidder

**ITEMS** supplied under this contract shall be subject to Panola County's approval. Items found defective or not meeting specifications shall be picked up and replaced by the successful bidder at no expense to the County. If item is not picked up within one (1) week after notification, the item will become a donation to the County for disposition.

**SAMPLES:** When requested, samples shall be furnished free of expense to Panola County.

**WARRANTY:** Successful bidder shall warrant that all items/services shall conform to the proposed specifications and/or all warranties as stated in the Uniform Commercial Code and be free from all defects in material, workmanship and title.

**REMEDIES:** The successful bidder and Panola County agree that both parties have all rights, duties, and remedies available as stated in the Uniform Commercial Code.

**VENUE:** This agreement will be governed and construed according to the laws of the State of Texas. This agreement is performable in Panola County, Texas.

**ASSIGNMENT:** The successful bidder shall not sell, assign, transfer or convey this contract, in whole or in part, without the prior written consent of Panola County.

**SILENCE OF SPECIFICATION:** The apparent silence of these specifications as to any detail or to the apparent omission from it of a detailed description concerning any point, shall be regarded as meaning that only the best commercial practices are to prevail. All interpretations of these specifications shall be made on the basis of this statement.

Each insurance policy to be furnished by successful bidder shall include, by endorsement to the policy, a statement that a notice shall be given to Panola County by certified mail thirty (30) days prior to cancellation or upon any material change in coverage.

CERTIFICATE OF INTERESTED PARTIES: Effective January 1, 2016 all contracts executed by Commissioners Court, regardless of the dollar amount, will require completion of Form 1295 "Certificate of Interested Parties", per Government Code Statute §2252.908. All vendors submitting a response to a formal Bid, or any contracts, contract amendments, renewals or change orders are required to complete the Form 1295 online through the State of Texas Ethics Commission website. Please visit, [https://www.ethics.state.tx.us/whatsnew/elf\\_info\\_form1295.htm](https://www.ethics.state.tx.us/whatsnew/elf_info_form1295.htm), for more information.

NO DISCRIMINATION: The Bidder must ensure that employees and applicants for employment are not discriminated against because of their race, color, religion, sex, or national origin.

---

Signature of Bidder

NON COLLUSION AFFIDAVIT: Each Bidder submitting a Bid to the County for any portion of the work contemplated by the documents on which bidding is based shall execute and attach thereto, an affidavit substantially in the form herein provided, to the effect that he has not entered into a collusive agreement with any other person, firm, or corporation in regard to any Bid submitted.

DISPOSAL AND HOLDHARMLESS: BIDDER SHALL LAWFULLY DISPOSE OF ALL CONSTRUCTION MATERIALS, CHEMICALS, AND DEBRIS AND SHALL INDEMNIFY AND HOLD OWNER HARMLESS FOR THE UNLAWFUL DISPOSAL OF ALL CONSTRUCTION MATERIALS, CHEMICALS, AND DEBRIS DONE BY BIDDER OR ITS SUBCONTRACTOR IN FURTHERANCE OF THIS BID.

SUPERVISION AND WARRANTY: The work shall be strictly supervised, the Bidder shall bear full responsibility for any and all acts or omissions of those engaged in the work on behalf of the Bidder; the Bidder hereby warrants that all labor furnished under this Bid shall be competent to perform the tasks undertaken, that the product of such labor shall yield only first-class results, that all materials and equipment provided shall be new and of high quality, that the completed work will be complete, of high quality, without defects, and that all work strictly complies with the requirements of this Bid. Any work not strictly complying with the requirements of this provision shall constitute a breach of the Bidder's warranty.

INDEMNITY:

THE BIDDER SHALL DEFEND, INDEMNIFY AND HOLD PANOLA COUNTY AND ALL ITS EMPLOYEES, OFFICIALS, AND AGENTS HARMLESS FROM ANY AND ALL CLAIMS, LIABILITY, DAMAGES, LOSS, COST AND EXPENSE OF EVERY TYPE WHATSOEVER INCLUDING, WITHOUT LIMITATION, ATTORNEYS' FEES AND EXPENSES, IN CONNECTION WITH THE BIDDER'S PERFORMANCE OF THIS BID, PROVIDED THAT SUCH CLAIMS, LIABILITY, DAMAGE, LOSS, COST OR EXPENSE IS DUE TO SICKNESS, PERSONAL INJURY, DISEASE OR DEATH, THE UNLAWFUL DISPOSAL OF CONSTRUCTION MATERIALS, CHEMICALS, OR DEBRIS, OR TO LOSS OR DESTRUCTION

OF TANGIBLE PROPERTY (OTHER THAN THE WORK ITSELF), INCLUDING LOSS OF USE RESULTING THERE FROM, TO THE EXTENT CAUSED BY THE BIDDER, OR ANYONE FOR WHOSE ACTS THE BIDDER MAY BE LIABLE, REGARDLESS OF WHETHER SUCH LIABILITY, CLAIM, DAMAGE, LOSS, COST OR EXPENSE IS CAUSED IN PART BY THE COUNTY.

Texas Government Code Sec. 2270.002 Provision Required in Contract:

1. Bidder does not boycott Israel; and
2. Bidder will not boycott Israel during the term of the contract.

ANY QUESTIONS concerning this INVITATION TO BID AND SPECIFICATIONS should be directed to **Melanie Earle, Road and Bridge Warehouse Coordinator at (903) 693-3763.**

---

Signature of Bidder

**SPECIFICATIONS AND BID FORM FOR CONCRETE / IRON ORE**

<b>TYPE</b>	<b>FOB</b>	<b>DELIVERED</b>
2" Minus Pure Crushed Concrete (PER YARD)	\$	\$
3 X 4 Pure Concrete (PER YARD)	\$	\$
2" Minus Crushed Iron Ore (PER YARD)	\$	\$

EXCEPTIONS \_\_\_\_\_

EXCEPTIONS \_\_\_\_\_

EXCEPTIONS \_\_\_\_\_

**F.O.B. (picked up) shall be to the closest location to the Panola County Warehouse. Delivery shall be to within a 25-mile radius of the Panola County Warehouse.**

Panola County will submit payment for the price bid per **CUBIC YARD** only. In determining the lowest and best bid, the Commissioners Court will consider the pick up and delivery locations of the bidders and the cost to the County of delivering or hauling the material to be purchased. So as to determine the most economical cost of the materials, Panola County will factor in a rate of fifty cents (\$.50) per yard per mile as a cost to the County for the materials to be picked up at the plant. No surcharge for hauling, fuel, etc... shall be included on invoices.

If the Commissioners Court considers awarding a contract to a bidder who is not the lowest bidder meeting specifications, the lowest dollar bidder will be given notice of the proposed award and will be given an opportunity to appear before the Commissioners Court to present evidence on the bidders behalf before the proposed bid is awarded.

Panola County shall provide as much advance notice as possible; however, supplier must be able to provide 90% of the orders as requested with a twelve (12) hour notice.

Bids shall be provided on this sheet.

The successful bidders will supply Panola County with a ticket indicating the number of **CUBIC YARDS** on each load delivered to Panola County at the time of the delivery. If the County picks up the material, the successful bidder shall provide necessary personnel and equipment to load the product along with a ticket, indicating the number of **CUBIC YARDS** picked up.

Samples of the above commodities may be taken as delivered or picked up at any time and submitted to a commercial testing laboratory for compliance. Commodities not meeting the above-described specifications must be removed by the supplier and will not be paid for.

ALL MATERIALS USED IN THESE PRODUCTS MUST COMPLY WITH STATE & FEDERAL ENVIRONMENTAL LAWS AND REGULATIONS.

THE ESTIMATED QUANTITY TO BE PURCHASED IS **2000 YARDS**. HOWEVER, THE COUNTY WILL NOT BE OBLIGATED TO PURCHASE THE ESTIMATED QUANTITY OR ANY OTHER PARTICULAR QUANTITY DURING THE YEAR.

DATE: \_\_\_\_\_

FIRM: \_\_\_\_\_

BY: \_\_\_\_\_

ADDRESS \_\_\_\_\_

\_\_\_\_\_

PHONE NUMBER: \_\_\_\_\_

DATE: \_\_\_\_\_

PANOLA COUNTY, TEXAS

BY: \_\_\_\_\_

PANOLA COUNTY, TEXAS

**INVITATION TO BID**

RETURN BID TO:

COUNTY JUDGE  
PANOLA COUNTY COURTHOUSE, ROOM 216A  
CARTHAGE, TEXAS 75633

The enclosed INVITATION TO BID (ITB) and accompanying SPECIFICATIONS AND BID SHEET are for your convenience in bidding the enclosed referenced service/products for Panola County.

Sealed bids shall be received no later than:

**1:30 P.M., TUESDAY, AUGUST 2, 2022.**

MARK ENVELOPE

**“GRAVEL”**

Bidder shall sign and date the bid. Bids, which are not signed and dated, can be rejected. Bids must be submitted on the enclosed bid sheets and must be in ink or typewritten.

Panola County appreciates your time and effort in preparing this bid. Please note that all bids must be received at the designated location by the deadline shown. Bids received after the deadline will not be considered for the award of the contract, and shall be considered void and unacceptable. Opening is scheduled to be held in Commissioners Courtroom, Panola County Courthouse, Carthage, Texas. You are invited to attend.

\_\_\_\_\_  
SIGNATURE OF BIDDER

**PANOLA COUNTY  
INVITATION TO BID**

**INSTRUCTIONS/TERMS OF CONTRACT**

By order of the Commissioners Court of Panola County, Texas, sealed bids will be received for:

**GRAVEL**

TO PROVIDE for an annual contract commencing **August 2, 2022** and continuing to **December 31, 2022**.

IT IS UNDERSTOOD that the Commissioners Court of Panola County, Texas reserves the right to reject any or all bids for any or all products and/or services covered in this bid request and to waive informalities or defects in bids or to accept such bids as it shall deem to be in the best interests of Panola County.

BIDS MUST BE submitted on the bid forms included for that purpose in this packet. Bids shall be placed in separate sealed envelopes, with **each page manually signed by a person having the authority to bind the firm in a contract** and marked clearly on the outside as shown below.

SUBMISSION OF BIDS: Sealed bids shall be submitted to:

**COUNTY JUDGE  
PANOLA COUNTY COURTHOUSE, ROOM 216A  
CARTHAGE, TEXAS 75633**

Not later than **1:30 P.M., TUESDAY, AUGUST 2, 2022**.

MARK ENVELOPES:

**“GRAVEL”**

**ALL BIDS MUST BE RECEIVED IN THE COUNTY JUDGE’S OFFICE  
BEFORE OPENING DATE AND TIME**

\_\_\_\_\_  
SIGNATURE OF BIDDER

INVITATION TO BID  
INSTRUCTIONS / TERMS OF CONTRACT

**FUNDING:** Funds for payment have been provided through the Panola County Budget adopted by the Commissioners Court for **August 2, 2022 thru December 31, 2022.**

**LATE BIDS:** Bids received in the County Judge's Office after submission deadline will be considered void and unacceptable. Panola County is not responsible for lateness or non-delivery of mail, carrier, etc.

**ALTERING BIDS:** Bids cannot be altered or amended after submission deadline. Any interlineation, alteration or erasure made before opening time must be initialed by the signer of the bid, guaranteeing authenticity.

**WITHDRAWAL OF BID:** A bid may not be withdrawn or canceled by the bidder without the permission of the county for a period of ninety (90) days following the date designated for the receipt of bids, and bidder so agrees upon submittal of their bid.

**SALES TAX:** Panola County is exempt by law from payment of Texas Sales Tax and Federal Excise Tax; therefore, the bid shall not include sales taxes.

**BID AWARD:** Panola County reserves the right to award bids on the lump sum or unit price basis, whichever is in the best interest of the county.

**CONTRACT:** This bid, when properly accepted by Panola County, shall constitute a contract equally binding between the successful bidder and Panola County. No different or additional terms will become a part of this contract with the exception of Change Orders.

**CHANGE ORDERS:** No oral statement of any person shall modify or otherwise change, or affect the terms, conditions or specifications stated in the resulting contract. All change orders to the contract will be made in writing by the Panola County Judge.

**IF DURING THE** life of the contract, the successful bidder's net prices to other customers for items awarded herein are reduced below the contracted price, it is understood and agreed that the benefits of such reduction shall be extended to Panola County.

**DELIVERY:** All delivery fees and freight or handling charges shall be as stated on the bid and contract forms section and if not so stated no such costs, fee or charge will be paid.

**CONFLICT OF INTEREST:** No public official shall have interest in this contract, in accordance with Vernon's Texas Codes Annotated, Local Government Code Title 5, Subtitle C, Chapter 171.

---

Signature of Bidder



**ETHICS:** The bidder shall not offer or accept gifts or anything of value nor enter into any business arrangement with any employee, official or agent of Panola County.

**EXCEPTIONS / SUBSTITUTIONS:** All bids meeting the intent of this invitation to bid will be considered for award. Bidders taking exception to the specifications, or offering substitutions, shall state these exceptions in the section provided or by attachment as part of the bid. The absence of such a list shall indicate that the bidder has not taken exceptions and shall hold the bidder responsible to perform in strict accordance with the specifications of the invitation. Panola County Commissioners Court reserves the right to accept any and all or none of the exceptions(s) / substitution(s) deemed to be in the best interest of the county.

**DESCRIPTIONS:** Any reference to model and/or make/manufacture used in bid specifications is descriptive, not restrictive. It is used to indicate the type and quality desired. Bids on items of like quality will be considered.

**ADDENDA:** Any interpretations, corrections or changes in this "Invitation To Bid and Specifications" will be made by addenda. Sole issuing authority of addenda shall be vested in Panola. Addenda will be mailed to all who are known to have received a copy of this Invitation To Bid. Bidders shall acknowledge receipt of all addenda.

**BIDS MUST COMPLY** with all federal, state, county and local laws concerning these types of service.

**DESIGN, STRENGTH, QUALITY** of materials must conform to the highest standards of manufacturing practice.

**MINIMUM STANDARDS FOR RESPONSIBLE PROSPECTIVE BIDDERS:** A prospective bidder must affirmatively demonstrate bidder's responsibility. A prospective bidder must meet the following requirements:

1. Have adequate financial resources, or the ability to obtain such resources as required;
2. be able to comply with the required or proposed delivery schedule;
3. Have a satisfactory record of performance;
4. Have a satisfactory record of integrity and ethics;
5. Be otherwise qualified and eligible to receive an award.

Panola County may request representation and other information sufficient to determine bidder's ability to meet these minimum standards listed above.

---

Signature of Bidder

**REFERENCES:** Panola County may request bidder to supply a list of at least three (3) references where like services/products have been supplied by their firm.

**BIDDER SHALL PROVIDE** with this bid response, all documentation required by this ITB. Failure to provide this information may result in rejection of bid.

**WAGES:** Successful bidder shall pay or cause to be paid, without cost or expense to Panola County, all Social Security, Unemployment and Federal Income Withholding Taxes of all such employees and all such employees shall be paid wages and benefits as required by Federal and/or State Law.

**TERMINATION OF CONTRACT:** This contract shall remain in effect until contract expires, delivery and acceptance of products and/or performance of services ordered or terminated by either party with a thirty (30) days written notice prior to any cancellation. The successful bidder must state therein the reasons for such cancellation. Panola County reserves the right to award canceled contract to next lowest and best bidder as it deems to be in the best interest of the county.

**PRICE CHANGES:** Prices are subject to change during the term of this contract. (See escalation/De-escalation below). Price changes will not be considered for the first sixty (60) days after the bid has been awarded.

**ESCALATION/DE-ESCALATION:** Where a bid is awarded with escalation/de-escalation pricing, the vendor is required to give a 30-day written notice before price increases. No notice requesting an increase in price shall be given or considered within the first 60 days after the bid has been awarded or a price has been escalated or de-escalated. Requested increase must be a factor beyond the control of the bidder and proof of increase must be documented and forwarded to the County Auditor. Notice of increase will be subject to approval by the Commissioners' Court before acceptance. Any contract awarded with an escalation clause shall be subject to de-escalation in the event of cost reduction.

**TERMINATION FOR DEFAULT:** Panola County reserves the right to enforce the performance of this contract in any manner prescribed by law or deemed to be in the best interest of the county in the event of breach or default of this contract. Panola County reserves the right to terminate the contract immediately in the event the successful bidder fails to:

1. Meet schedules;
2. Defaults in the payment of any fees; or
3. Otherwise perform in accordance with these specifications.

Breach of contract or default authorizes the county to exercise any of all of the following rights:

1. Panola County may take possession of the assigned premises and any fees accrued or becoming due to date.

2. Panola County may take possession of all goods, fixtures and materials of successful bidder therein and may foreclose its lien against such personal property, applying the proceeds toward fees due or thereafter becoming due.

---

Signature of Bidder

In the event the successful bidder shall fail to perform, keep or observe any of the terms and conditions to be performed, kept or observed, Panola County shall give the successful bidder written notice of such default; and in the event said default is not remedied to the satisfaction and approval of the county within two (2) working days of receipt of such notice by the successful bidder, default will be declared and all the successful bidder's rights shall terminate.

Bidder, in submitting this bid, agrees that Panola County shall not be liable to prosecution for damages in the event that the county declares the bidder in default.

**NOTICE:** Any notice provided by this bid (or required by Law) to be given to the successful bidder by Panola County shall be conclusively deemed to have been given and received on the next day after such written notice has been deposited in the mail in Carthage, Texas, by Registered or Certified Mail with sufficient postage affixed thereto, addressed to the successful bidder at the address so provided; provided this shall not prevent the giving of actual notice in any other manner.

**PATENTS / COPYRIGHTS:** The successful bidder agrees to protect Panola County from claims involving infringement of patents and/or copyrights.

**CONTRACT ADMINISTRATOR:** Under this contract, Panola County may appoint a contract administrator with designated responsibility to ensure compliance with contract requirements. The contract administrator will serve as liaison between Panola County and the successful bidder.

**PURCHASE ORDER:** A purchase order(s) shall be generated by Panola County to the successful bidder. The purchase order number must appear on all itemized invoices and packing slips. Panola County will not be held responsible for any orders placed/delivered without a valid current purchase order number.

**INVOICES** shall show (a) name and address of successful bidder, (b) Panola County Purchase Order number, and (c) descriptive information as to the item(s) delivered.

**PAYMENT** will be made upon receipt and acceptance by the county of item(s) ordered and receipt of a valid invoice, in accordance with the State of Texas Prompt Payment Act,

Government Code Chapter 2251. Successful bidder is required to pay subcontractors within ten (10) days.

---

Signature of Bidder

**ITEMS** supplied under this contract shall be subject to Panola County's approval. Items found defective or not meeting specifications shall be picked up and replaced by the successful bidder at no expense to the County. If item is not picked up within one (1) week after notification, the item will become a donation to the County for disposition.

**SAMPLES:** When requested, samples shall be furnished free of expense to Panola County.

**WARRANTY:** Successful bidder shall warrant that all items/services shall conform to the proposed specifications and/or all warranties as stated in the Uniform Commercial Code and be free from all defects in material, workmanship and title.

**REMEDIES:** The successful bidder and Panola County agree that both parties have all rights, duties, and remedies available as stated in the Uniform Commercial Code.

**VENUE:** This agreement will be governed and construed according to the laws of the State of Texas. This agreement is performable in Panola County, Texas.

**ASSIGNMENT:** The successful bidder shall not sell, assign, transfer or convey this contract, in whole or in part, without the prior written consent of Panola County.

**SILENCE OF SPECIFICATION:** The apparent silence of these specifications as to any detail or to the apparent omission from it of a detailed description concerning any point, shall be regarded as meaning that only the best commercial practices are to prevail. All interpretations of these specifications shall be made on the basis of this statement.

Each insurance policy to be furnished by successful bidder shall include, by endorsement to the policy, a statement that a notice shall be given to Panola County by certified mail thirty (30) days prior to cancellation or upon any material change in coverage.

**CERTIFICATE OF INTERESTED PARTIES:** Effective January 1, 2016 all contracts executed by Commissioners Court, regardless of the dollar amount, will require completion of Form 1295 "Certificate of Interested Parties", per Government Code Statute §2252.908. All vendors submitting a response to a formal Bid, or any contracts, contract amendments, renewals or change orders are required to complete the Form 1295 online through the State of Texas Ethics

Commission website. Please visit,  
[https://www.ethics.state.tx.us/whatsnew/elf\\_info\\_form1295.htm](https://www.ethics.state.tx.us/whatsnew/elf_info_form1295.htm), for more information.

**NO DISCRIMINATION:** The Bidder must ensure that employees and applicants for employment are not discriminated against because of their race, color, religion, sex, or national origin.

---

Signature of Bidder

**NON COLLUSION AFFIDAVIT:** Each Bidder submitting a Bid to the County for any portion of the work contemplated by the documents on which bidding is based shall execute and attach thereto, an affidavit substantially in the form herein provided, to the effect that he has not entered into a collusive agreement with any other person, firm, or corporation in regard to any Bid submitted.

**DISPOSAL AND HOLDHARMLESS:** BIDDER SHALL LAWFULLY DISPOSE OF ALL CONSTRUCTION MATERIALS, CHEMICALS, AND DEBRIS AND SHALL INDEMNIFY AND HOLD OWNER HARMLESS FOR THE UNLAWFUL DISPOSAL OF ALL CONSTRUCTION MATERIALS, CHEMICALS, AND DEBRIS DONE BY BIDDER OR ITS SUBCONTRACTOR IN FURTHERANCE OF THIS BID.

**SUPERVISION AND WARRANTY:** The work shall be strictly supervised, the Bidder shall bear full responsibility for any and all acts or omissions of those engaged in the work on behalf of the Bidder; the Bidder hereby warrants that all labor furnished under this Bid shall be competent to perform the tasks undertaken, that the product of such labor shall yield only first-class results, that all materials and equipment provided shall be new and of high quality, that the completed work will be complete, of high quality, without defects, and that all work strictly complies with the requirements of this Bid. Any work not strictly complying with the requirements of this provision shall constitute a breach of the Bidder's warranty.

**INDEMNITY:**  
THE BIDDER SHALL DEFEND, INDEMNIFY AND HOLD PANOLA COUNTY AND ALL ITS EMPLOYEES, OFFICIALS, AND AGENTS HARMLESS FROM ANY AND ALL CLAIMS, LIABILITY, DAMAGES, LOSS, COST AND EXPENSE OF EVERY TYPE WHATSOEVER INCLUDING, WITHOUT LIMITATION, ATTORNEYS' FEES AND EXPENSES, IN CONNECTION WITH THE BIDDER'S PERFORMANCE OF THIS BID, PROVIDED THAT SUCH CLAIMS, LIABILITY, DAMAGE, LOSS, COST OR EXPENSE IS DUE TO SICKNESS, PERSONAL INJURY, DISEASE OR DEATH, THE UNLAWFUL DISPOSAL OF CONSTRUCTION MATERIALS, CHEMICALS, OR DEBRIS, OR TO LOSS OR DESTRUCTION OF TANGIBLE PROPERTY (OTHER THAN THE WORK ITSELF), INCLUDING LOSS OF USE RESULTING THERE FROM, TO THE EXTENT CAUSED BY THE BIDDER, OR ANYONE FOR WHOSE ACTS THE BIDDER MAY BE LIABLE, REGARDLESS OF WHETHER

SUCH LIABILITY, CLAIM, DAMAGE, LOSS, COST OR EXPENSE IS  
CAUSED IN PART BY THE COUNTY.

Texas Government Code Sec. 2270.002 Provision Required in Contract:

- (1) Bidder does not boycott Israel; and
- (2) Bidder will not boycott Israel during the term of the contract.

ANY QUESTIONS concerning this INVITATION TO BID AND SPECIFICATIONS should be  
directed to **Melanie Earle, Road and Bridge Warehouse Coordinator at (903) 693-3763.**

---

Signature of Bidder

**SPECIFICATIONS AND BID FORM FOR GRAVEL**

<b>TYPE</b>	<b>F.O.B.</b>	<b>DELIVERED</b>
Arkansas SB-2 (PER YARDS)	\$	\$
Arkansas 2 1/2" D-Ballast (PER YARDS)	\$	\$
Arkansas Rip Rap (PER YARDS)	\$	\$
3"x5" Georgetown rock (PER YARDS)	\$	\$

EXCEPTIONS \_\_\_\_\_

\_\_\_\_\_

\_\_\_\_\_

\_\_\_\_\_

\_\_\_\_\_

**F.O.B. (picked up) shall be to the closest location to the Panola County Warehouse. Delivery shall be to within a 25-mile radius of the Panola County Warehouse.**

In determining the lowest and best bid, the Commissioners Court will consider the pick-up and delivery locations of the cost to the County of delivering or hauling the material to be purchased. So as to determine the most economical cost of the materials, Panola County will factor in a rate of fifty cents (.50) per yard/per mile as a cost to the County for materials to be picked up at the plant.

If the Commissioners Court considers awarding a contract to a bidder who is not the lowest bidder meeting specifications, the lowest dollar bidder will be given notice of the proposed award and will be given an opportunity to appear before the Commissioners Court to present evidence on the bidders behalf before the proposed bid is awarded.

Panola County shall provide as much advance notice as possible; however, supplier must be able to provide 90% of the orders as requested with a twelve (12) hour notice.

Bids shall be provided on this sheet.

The successful bidders will supply Panola County with a ticket indicating the number of **CUBIC YARDS** on each load delivered to Panola County at the time of the delivery. If the County picks up the material, the successful bidder shall provide necessary personnel and equipment to load the product along with a ticket, indicating the number of **CUBIC YARDS** picked up.

Samples of the above commodities may be taken as delivered or picked up at any time and submitted to a commercial testing laboratory for compliance. Commodities not meeting the above-described specifications must be removed by the supplier and will not be paid for.

**ALL MATERIALS USED IN THESE PRODUCTS MUST COMPLY WITH STATE & FEDERAL ENVIRONMENTAL LAWS AND REGULATIONS.**

**THE ESTIMATED QUANTITY TO BE PURCHASED IS 2000 YARDS. HOWEVER, THE COUNTY WILL NOT BE OBLIGATED TO PURCHASE THE ESTIMATED QUANTITY OR ANY OTHER PARTICULAR QUANTITY DURING THE YEAR.**



DATE: \_\_\_\_\_

FIRM: \_\_\_\_\_

BY: \_\_\_\_\_

ADDRESS \_\_\_\_\_

\_\_\_\_\_

PHONE NUMBER: \_\_\_\_\_

DATE: \_\_\_\_\_

PANOLA COUNTY, TEXAS

BY: \_\_\_\_\_

Form #2201 Rev. 09/2017  
Submit to:  
**SECRETARY OF STATE**  
Government Filings  
Section P O Box 12887  
Austin, TX 78711-2887  
512-463-6334  
512-463-5569 - Fax  
Filing Fee: None



**STATEMENT OF OFFICER**

FILED FOR RECORD  
IN MY OFFICE  
AT 2:30 O'CLOCK P M  
  
AUG 03 2022  
  
BOBBIE DAVIS  
COUNTY CLERK, PANOLA COUNTY, TEXAS  
BY B. Davis DEPUTY

**Statement**

I, Kirstyn Jacks, do solemnly swear (or affirm) that I have not directly or indirectly paid, offered, promised to pay, contributed, or promised to contribute any money or thing of value, or promised any public office or employment for the giving or withholding of a vote at the election at which I was elected or as a reward to secure my appointment or confirmation, whichever the case may be, so help me God.

Title of Position to Which Elected/Appointed: Tax Assessor-Collector/Auto Registration Deputy Clerk

**Execution**

Under penalties of perjury, I declare that I have read the foregoing statement and that the facts stated therein are true.

Date: 6-28-22

Kirstyn Jacks  
Signature of Officer

Form #2204 Rev 9/2017

Submit to:  
SECRETARY OF STATE  
Government Filings Section  
P O Box 12887  
Austin, TX 78711-2887  
512-463-6334  
FAX 512-463-5569  
Filing Fee: None



OATH OF OFFICE

This space reserved for office use  
FILED FOR RECORD  
IN MY OFFICE

AT 2:30 O'CLOCK P M

AUG 03 2022

BOBBIE DAVIS  
COUNTY CLERK, PANOLA COUNTY, TEXAS  
BY B. Davis DEPUTY

IN THE NAME AND BY THE AUTHORITY OF THE STATE OF TEXAS,  
I, Kirstyn Jacks, do solemnly swear (or affirm), that I will faithfully  
execute the duties of the office of Tax Assessor-Collector/Auto Registration Deputy Clerk of  
the State of Texas, and will to the best of my ability preserve, protect, and defend the Constitution and laws  
of the United States and of this State, so help me God.

Kirstyn Jacks  
Signature of Officer

Certification of Person Authorized to Administer Oath

State of Texas  
County of Panola

Sworn to and subscribed before me on this 28th day of June, 2022.

(Affix Notary Seal,  
only if oath  
administered by a  
notary.)

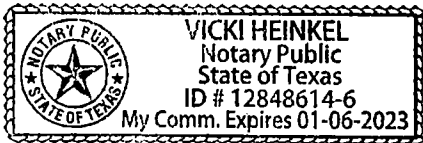

Vicki Heinkel  
Signature of Notary Public or  
Signature of Other Person Authorized to Administer An  
Oath

Vicki Heinkel  
Printed or Typed Name

## Panola County Emergency Services District #1

P.O. Box 294  
1509 W. Panola (Administrative Office)  
Carthage, TX 75633

June 28, 2022

The Honorable David Anderson, County Judge for Panola County  
110 S. Sycamore St. Room 216-A  
Carthage, TX 75633

Dear Judge Anderson:

Per Section 775.036(a)(4) of the Health & safety Code, we are proving this letter and attached financial statements as of December 31, 2021 for the Panola County Emergency Services District #1. Our firm prepared the financial statements for the district. This information is being provided to comply with state statute and serves as our initial submission of a financial report. The Panola County Emergency Services District #1 will also have an annual audit. Once that audit is completed, we will provide you with a copy and it can serve as supplemental additional information to the report that we are submitting today. The audit will be prepared by Rachel Payne CPA here in Carthage. The attached financial statements main difference from the final audit numbers will be related to depreciation. The audit will also be presented in the updated reporting format requirements of the AICPA.

The attached financial statements are in the same format that the PCESD#1 has used for many years. The district experienced no unusual items for 2021. The district purchased no major items for 2021. The district has dropped plans for a new station on FM 31 due to uncertainty as to cost. For 2022, the district is considering purchasing up to 5 new units which will be a very substantial investment. The district maintains ample reserves in case of an emergency.

As is reflected in the financial statements, the district had cash reserves of \$2,077,587 in CD'S and checking accounts as of 12/31/21. Year end balances are normally the highest point of the year due to the collection of current year tax revenues.

The district's budget for 2021 was \$937,311 (up \$96,379 from 2020) in revenues and \$937,311 in expenditures of which \$316,911 was designated for contingency items. As the financial statements reflect, actual revenues were \$1,197,995 including interest income, insurance proceeds, and a \$128,645 PPP Extractor Grant. Actual expenditures were \$762,281. The excess of revenue over expenditures were added back to net reserves of the ESD. The revenues were based on tax rate of .02842% which was the roll back rate and which is 5.3% below our statutory maximum of .03%. Due to future replacement of unites, the district has been moving up to the roll back rate the past few years. As has been consistent with prior years, the district has no outstanding debt and thus no debt service.

The continued support of county officials is greatly appreciated. If you have any questions or need any additional information, don't hesitate to let us know.

Respectfully Submitted;  
Drew Nixon, CPA for Nixon & Woodfin CPAs  
Cc: PCESD#1 Commissioners



After Audit Adj.

Financial Statements

Minp Before Recheck

of  
PANOLA COUNTY EMERGENCY SERVICES DIST #1  
For the Period Ended December 31, 2021

FOR MANAGEMENT USE ONLY

**PANOLA COUNTY EMERGENCY SERVICES DIST #1**  
**Statement of Net Assets**  
**December 31, 2021**

**ASSETS**

**Current Assets**

FSB - First State Bank #84700	\$	1,377,486.79	
Clearing from Tax Assessor		81,307.01 ✓	
Cash in Bank- Inter Comm VFD		2,463.00	
Cash in Bank- Flatwoods VFD		23,862.89	
Cash in Bank- Woods VFD		13,094.75	
Cash in Bank- Clayton VFD		23,045.63	
Cash in Bank- Beckville VFD		13,245.82	
Cash in Bank- Gary VFD		35,836.12	
Cash in Bank- Comm Four FSB		6,670.12	
Prepaid Insurance		<u>54,910.59</u> ✓	
<b>Total Current Assets</b>	<b>\$</b>		<b>1,631,922.72</b>

**Fixed Assets**

Delinquent Taxes Receivable		50,264.38 ✓	
Allow. for Uncollectable 25%		(12,566.10) ✓	
Fixed Assets- Equipment		5,892,922.78	
Fixed Assets- Building		612,077.47	
Construction in Progress		17,927.58	
Land		40,888.80	
Accumulated Depreciation		<u>(5,319,311.50)</u>	
<b>Total Fixed Assets</b>			<b>1,282,203.41</b>

**Other Assets**

Director's Bond		100.00	
FSB-CD#02069 \$100,000 05/22/23		100,000.00	
FSB-CD#02292 \$100,000 01/22/23		100,000.00	
FSB-CD#02211 \$100,000 06/20/22		100,000.00	
FSB-CD#02212 \$100,000 06/24/22		100,000.00	
FSB-CD#02253 \$100,000 10/26/22		100,000.00	
FSB-CD#02243 \$200,000 09/18/22		<u>200,000.00</u>	
<b>Total Other Assets</b>			<u><b>700,100.00</b></u>
<b>Total Assets</b>	<b>\$</b>		<u><u><b>3,614,226.13</b></u></u>

**PANOLA COUNTY EMERGENCY SERVICES DIST #1**  
**Statement of Net Assets**  
**December 31, 2021**

**LIABILITIES AND EQUITY**

**Current Liabilities**

Upcoming Year Tax Revenue \$ 680,711.18 ✓

**Total Current Liabilities** \$ 680,711.18

**Net Assets**

Unrestricted Net Assets 1,254,829.31

Restricted Net Assets for Cap. 1,236,085.85

Current Income (Loss) 442,599.79

**Total Net Assets** 2,933,514.95

**Total Liabilities & Equity** \$ 3,614,226.13

**PANOLA COUNTY EMERGENCY SERVICES DIST #1**  
**Statement of Activities**  
**For the Period Ended December 31, 2021**

	12 Months Ended Dec. 31, 2021	Budget	Variance	Pct
<b>General Revenue</b>				
Property Tax-Current Yr.	\$ 980,004.91	\$ 933,311.00	\$ 46,693.91	5
Property Tax-Delinquent	38,061.45	0.00	38,061.45	0
Misc. Revenue	233.37	0.00	233.37	0
Insurance Refund- Workers Comp	2,747.00	0.00	2,747.00	0
PPP Grant Extractor	128,645.10	0.00	128,645.10	0
Contributions	750.00	0.00	750.00	0
Ins. Income-Tornado Flatwoods	47,552.75	0.00	47,552.75	0
<b>Total General Revenue</b>	<b>1,197,994.58</b>	<b>933,311.00</b>	<b>264,683.58</b>	<b>28</b>
<b>Operating &amp; Capital Expenses</b>				
Dept-Inter Comm VFD	33,525.14	28,200.00	5,325.14	19
Dept-Flatwoods VFD	27,943.90	28,200.00	(256.10)	(1)
Dept-Woods VFD	16,869.36	28,200.00	(11,330.64)	(40)
Dept-Clayton VFD	22,810.29	28,200.00	(5,389.71)	(19)
Dept-BeckvilleVFD	33,830.49	28,200.00	5,630.49	20
Dept-Comm Four VFD	27,412.91	28,200.00	(787.09)	(3)
Dept-Gary VFD	23,176.25	28,200.00	(5,023.75)	(18)
Run- Tatum VFD	4,000.00	4,000.00	0.00	0
Run- Carthage VFD	9,300.00	16,000.00	(6,700.00)	(42)
Capital Imp-Beckville	37,485.00	40,000.00	(2,515.00)	(6)
Capital Imp-Clayton	23,291.20	32,500.00	(9,208.80)	(28)
Capital Imp-Gary	15,394.02	24,000.00	(8,605.98)	(36)
Capital Imp-Inter Comm	17,130.63	17,500.00	(369.37)	(2)
Capital Imp-Woods	37,020.79	60,500.00	(23,479.21)	(39)
Capital Imp-Comm Four	32,807.44	40,000.00	(7,192.56)	(18)
Capital Imp-Flatwoods	21,100.44	22,000.00	(899.56)	(4)
ESD Training Grant Money	4,100.00	0.00	4,100.00	0
ESD Radio Grant-Comm Four	7,495.44	0.00	7,495.44	0
<b>Total Operating &amp; Capital</b>	<b>394,693.30</b>	<b>453,900.00</b>	<b>(59,206.70)</b>	<b>(13)</b>
<b>Gross Profit</b>	<b>803,301.28</b>	<b>479,411.00</b>	<b>323,890.28</b>	<b>68</b>
<b>Board Expenses</b>				
Tax Appraisal Assesment	12,071.25	10,000.00	2,071.25	21
Agenda Posting/Legal Notices	1,575.88	1,000.00	575.88	58
Tax Collection Attorney Fees	0.00	4,000.00	(4,000.00)	(100)
Tax Collector Fees	11,009.17	10,000.00	1,009.17	10
Dues & Subscriptions	1,400.00	2,500.00	(1,100.00)	(44)
PPP Grant Expenses Extractors	128,645.10	0.00	128,645.10	0
Insurance	67,223.55	60,000.00	7,223.55	12
Meals	780.00	0.00	780.00	0
Office Supplies & Postage	623.39	1,000.00	(376.61)	(38)
Professional & Legal Fees	53,752.19	75,000.00	(21,247.81)	(28)
Training	0.00	3,000.00	(3,000.00)	(100)
Tornado Damage-Flatwoods VFD	17,954.49	0.00	17,954.49	0

FOR MANAGEMENT USE ONLY



	12 Months Ended Dec. 31, 2021	Budget	Variance	Pct
Contingency	<u>72,553.00</u>	<u>316,911.00</u>	<u>(244,358.00)</u>	<u>(77)</u>
<b>Total Board Expenses</b>	<u>367,588.02</u>	<u>483,411.00</u>	<u>(115,822.98)</u>	<u>(24)</u>
<b>Operating Income</b>	435,713.26	(4,000.00)	439,713.26	(999)
Interest Income	<u>6,886.53</u>	<u>4,000.00</u>	<u>2,886.53</u>	<u>72</u>
<b>Total Other Income</b>	<u>6,886.53</u>	<u>4,000.00</u>	<u>2,886.53</u>	<u>72</u>
<b>Net Income (Loss)</b>	\$ <u>442,599.79</u>	\$ <u>0.00</u>	\$ <u>442,599.79</u>	<u>0</u>



PANOLA COUNTY OFFICIAL/EMPLOYEE  
REQUEST FOR ATTENDANCE  
AT A CONFERENCE

APPROVED

07-05-22



David L. Anderson  
County Judge

NAME:

Jackie McDonald

POSITION:

Deputy County Clerk

DEPARTMENT:

County Clerk

DATE:

6/21/2022

CONFERENCE:

Texas College of Probate Judges Conf.

LOCATION:

San Antonio, TX

DATES:

Aug 31, 2022 to Sept 2, 2022

NUMBER OF DAYS OUT OF OFFICE FOR THIS CONFERENCE:

3

Does the conference meet your educational requirements for the year? n/a

If not, how much of your requirements will be met by this conference? n/a

How much of your requirements have been met already, not counting this conference? n/a

How many days have you been away from your job this year for conferences, not counting this conference? n/a

Do you have sufficient funds in your budget for this conference? yes

Write a short statement explaining the public purpose that will be met by your attendance at this conference: (continue on the back if necessary.)

This conference educates and updates  
on probates, estates and guardianship  
laws.

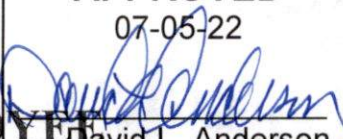
**APPROVED**  
07-05-22  
  
David L. Anderson  
County Judge

**PANOLA COUNTY OFFICIAL/EMPLOYEE  
REQUEST FOR ATTENDANCE AT A CONFERENCE**

NAME: KAYLEE SPARKS  
POSITION: TELECOMMUNICATIONS OPERATOR  
DEPARTMENT: Panola County Sheriff Office  
DATE: 06/21/2022

CONFERENCE: PUBLIC SAFETY TELECOMMUNICATOR  
LOCATION: PANOLA COUNTY  
DATES: ONLINE to ONLINE

NUMBER OF DAYS OUT OF THE OFFICE FOR THIS CONFERENCE: 0

Does the conference meet your educational requirements for the year? NO

If not, how much of your requirements will be met by this conference? 80HRS

How much of your requirements have been met already, not counting this conference?  
NONE

How many days have you been away from your job this year for conferences, not counting this conference? NONE

Do you have sufficient funds in your budget for this conference? YES

Write a short statement explaining the public purpose that will be met by your attendance at this conference: (continue on the back if necessary.)

REQUIREMENT FOR STATE LICENSE  
\_\_\_\_\_  
\_\_\_\_\_  
\_\_\_\_\_  
\_\_\_\_\_

APPROVED

07-05-22



David L. Anderson  
County Judge

# PANOLA COUNTY OFFICIAL/EMPLOYEE REQUEST FOR ATTENDANCE AT A CONFERENCE

NAME: MARISSA HARRISON  
POSITION: TELECOMMUNICATIONS OPERATOR  
DEPARTMENT: Panola County Sheriff Office  
DATE: 06/21/2022

CONFERENCE: PUBLIC SAFETY TELECOMMUNICATOR  
LOCATION: PANOLA COUNTY  
DATES: ONLINE to ONLINE

NUMBER OF DAYS OUT OF THE OFFICE FOR THIS CONFERENCE: 0

Does the conference meet your educational requirements for the year? NO

If not, how much of your requirements will be met by this conference? 80HRS

How much of your requirements have been met already, not counting this conference?  
NONE

How many days have you been away from your job this year for conferences, not counting this conference? NONE

Do you have sufficient funds in your budget for this conference? YES

Write a short statement explaining the public purpose that will be met by your attendance at this conference: (continue on the back if necessary.)

REQUIREMENT FOR STATE LICENSE  
\_\_\_\_\_  
\_\_\_\_\_  
\_\_\_\_\_  
\_\_\_\_\_